

Manual Valve DN 4 - 15 mm (1/4" - 1/2")



KMA 205, S01

Features

- **Stainless steel bonnet and plastic hand wheel**
- Manual diaphragm Valve with plastic hand wheel is suitable for a limited number of cycles of autoclaving.
- Rising hand wheel
- Sealed bonnet with optical indicator
- Adjustable internal travel stop
- CDSA sealing concept, see page 32
- Flexible diaphragm suspension

Specific features S02

- Adjustable internal stroke limiter
- Locking device

Optional features S02

- U-Lock for hand wheel
- Assembly of proximity switches



KMA 205, S02

Technical Data

Control function:	Manually operated
Max. working pressure:	10 bar (150 psi)
Max. working temperature:	160°C (320°F) dependent on application
Diaphragm material:	EPDM or PTFE
Body material:	Forged 1.4435/ 316L ASME/BPE Investment cast 1.4435/ 316L Other Alloys
End connection:	Butt weld ends see fold out page 21 Clamps and flanges see page 22 and 23 Special ends
Bonnets suitable for:	Two-Way bodies Welded configurations T- bodies Multiport bodies Tank bottom bodies
Flow rate:	Kv in m ³ /h (Cv in GPM) see page 9
Diaphragm size:	MA 8
Weight:	205: ca. 0,2 kg

Technical data also valid for multiport valve.

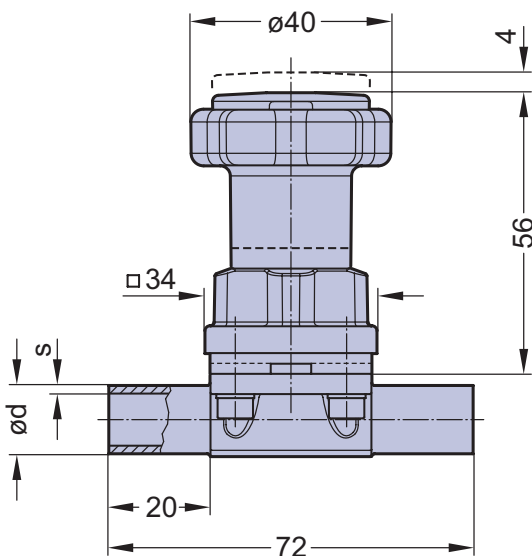

KMA 205

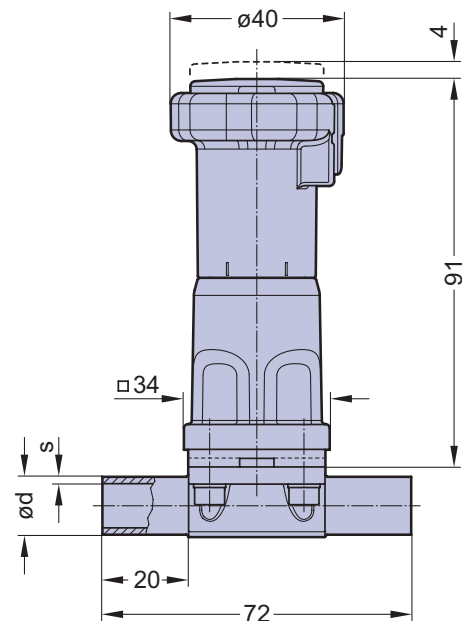

KMA 205

Valve type overview see page 26 and 27.
Ordering key see page 59 to 61..