



Fig. 1 · Type 3321 Valve with mounted rod-type yoke for pneumatic and electric actuators (partial view)

Mounting and Operating Instructions

EB 8111/8112 EN

Edition August 2006



Contents	Page
1	Design and principle of operation 4
	Technical data 6
2	Installation 7
2.1	Assembling valve and actuator 7
2.2	Mounting position 10
2.3	Strainer. 10
3	Operation 10
4	Maintenance – Replacing parts 10
4.1	Packing. 11
4.2	Plug 11
4.3	Seat 12
5	Description of nameplate 13
6	Dimensions and weights 14
7	Customer inquiries 15

Note!

*Non-electrical control valves which do not have a valve body lined with an insulating material coating do not have their own potential ignition source according to the risk assessment in the rare incident of an operating fault, corresponding to EN 13463-1: 2001 paragraph 5.2, and therefore do **not** fall within the scope of the European Directive 94/9/EC.*

Refer to paragraph 6.3 of EN 60079-14:1977 VDE 0165 Part 1 concerning connection to equipotential bonding system.



General safety instructions

- ▶ The control valve may only be mounted, started up or serviced by fully trained and qualified personnel, observing the accepted industry codes and practices. Make sure employees or third persons are not exposed to any danger. All safety instructions and warnings in these mounting and operating instructions, particularly those concerning assembly, start-up and maintenance, must be observed.
- ▶ The control valves fulfill the requirements of the European Pressure Equipment Directive 97/23/EC. Valves with a CE marking have a declaration of conformity that includes information about the applied conformity assessment procedure. The declaration of conformity is available on request.
- ▶ For appropriate operation, make sure that the control valve is only used in areas where the operating pressure and temperatures do not exceed the operating values which are based on the valve sizing data submitted in the order. The manufacturer does not assume any responsibility for damage caused by external forces or any other external influence! Any hazards which could be caused in the control valve by the process medium, operating pressure, signal pressure or by moving parts are to be prevented by means of the appropriate measures.
- ▶ Proper shipping and appropriate storage are assumed.

Caution!

- ▶ For installation and maintenance work on the valve, make sure the relevant section of the pipeline is depressurized and, depending on the process medium, drained as well. If necessary, allow the control valve to cool down or warm up to reach ambient temperature prior to starting any work on the valve.
- ▶ Prior to performing any work on the valve, make sure the supply air and control signal are disconnected or blocked to prevent any hazards that could be caused by moving parts.
- ▶ Special care is needed when the actuator springs are pretensioned. These actuators are labeled correspondingly and can also be identified by three long bolts at the bottom of the actuator. Prior to starting any work on the valve, you must relieve the compression from the pretensioned springs.

1 Design and principle of operation

The Type 3321 Globe Valve is designed based on the modular principle and can be combined with pneumatic as well as electric actuators as listed in Table 1.

The process medium flows through the valve in the direction indicated by the arrow. The valve plug position determines the cross-sectional

area of flow between the seat (2) and the plug (3).

The position of the plug is changed by the control signal acting on the actuator.

The plug stem is sealed by a spring-loaded PTFE V-ring packing (4.2) and connected to the actuator stem (8.1) by a stem connector (7).

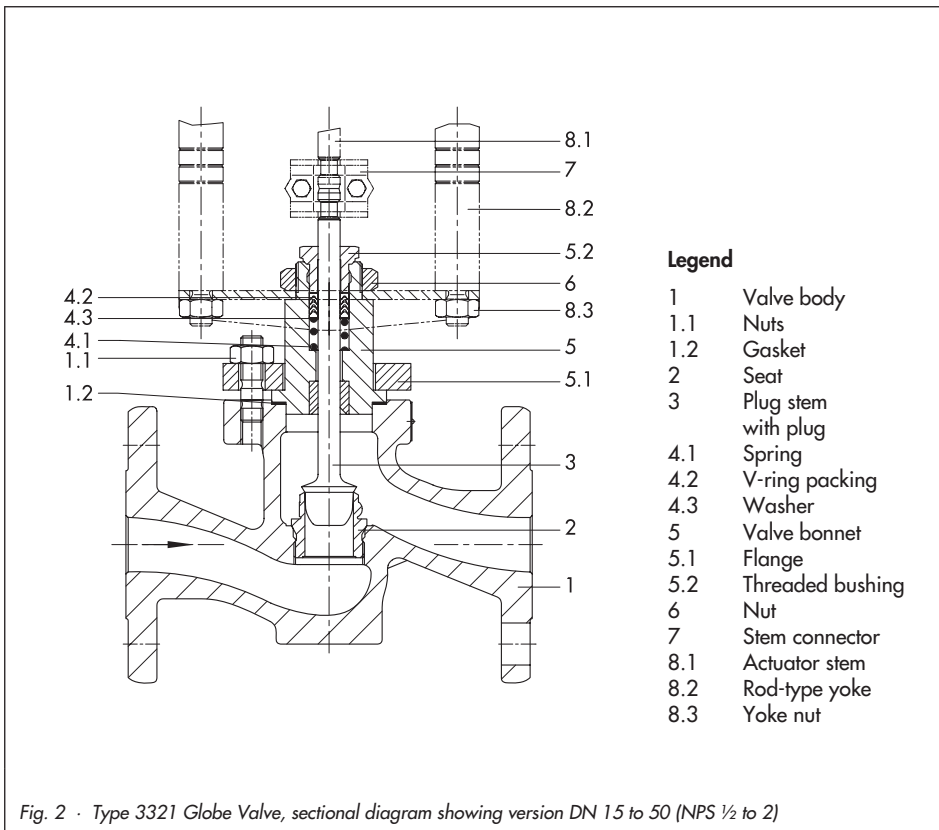

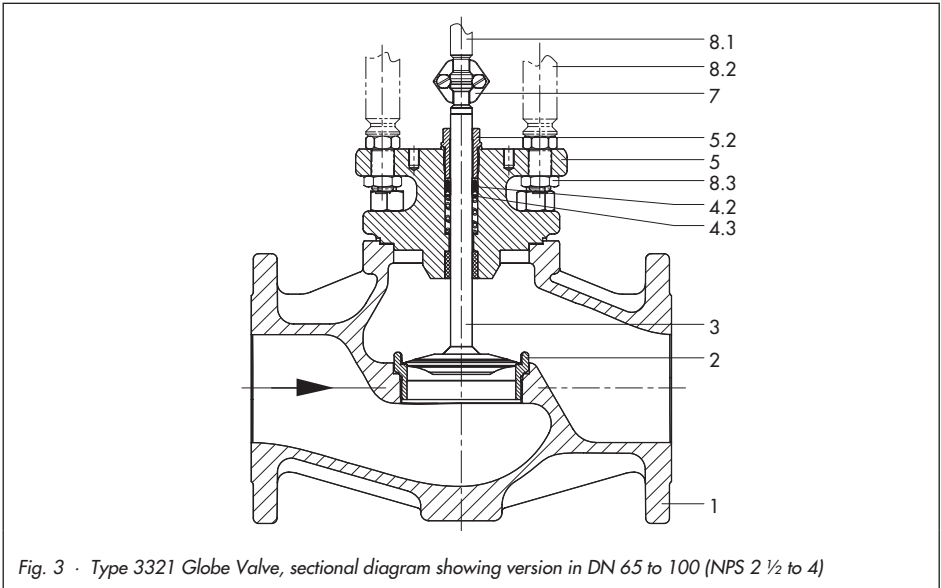

Table 1 · Actuators for Type 3321 Valve

Nominal size		DN	15	20	25	32	40	50	65	80	100	
		NPS	½	¾	1	–	1½	2	2½	3	4	
Rated travel		mm	15								15/30	
Actuator	Pneumatic	Type 3371	120 cm ²	•	•	•	•	•	•	•	•	–
			350 cm ²	–						•	•	•
		Type 3372	120 cm ²	•	•	•	•	•	•	• ¹⁾	• ¹⁾	
			350 cm ²	–						•	•	•
	Electric	Type 5824		•	•	•	•	•	•	–		
		Type 3374		•	•	•	•	•	•	• ²⁾	• ²⁾	• ²⁾

¹⁾ Actuator not in electropneumatic version

²⁾ Only with Type 3374-10 and Type 3374-15

1.1 Technical data

Nominal size		DN 15 to 100 · NPS ½ to 4		
Body material	DIN	Cast iron · EN-JL1040	Cast steel 1.0619	Stainless steel 1.4581
	ASTM	Cast iron · A 126 B	Carbon steel A 216 WCC	Stainless steel A 351 CF8M
End connections	Flanges	DIN EN 1092-2	DIN EN 1092-1	
	ANSI	Flat face $R_a = 3.2 \dots 6.3 \mu\text{m}$	Raised face $R_a = 3.2 \dots 6.3 \mu\text{m}$	
Nominal pressure	PN	10 · 6	16 · 40	16 · 40 ¹⁾
	ANSI Class	125	150 · 300	
Seat/plug sealing	Metal or soft sealing			
Characteristic	Equal percentage			
Rangeability	50 : 1		50 : 1	
Temperature range	-10 ... 220 °C · 14 ... 430 °F			
Leakage class acc. to DIN EN 1349	Metal sealing: IV Soft sealing: VI			
Materials				
Bonnet	DIN	1.0460	≤DN 50: 1.0305 ≥DN 65: 1.0619	≤DN 50: 1.4571 ≥DN 65: 1.4408
	ANSI	A 105	≤NPS 2: A 105 ≥NPS 2½: A216WCC	≤NPS 2: A316Ti ≥NPS 2½: A351CF8M
Seat	DIN/ANSI	1.4305 or 1.4104 · 1.4006 ²⁾		
Plug	DIN	DN 50 and smaller: 1.4305 · DN 65 and larger: 1.4404		
	ANSI	NPS 2 and smaller: 1.4305 · NPS 2½ and larger: 1.4404		
Sealing ring w. soft sealing	PTFE			
Guided bushing	1.4104			
Packing	V-ring packing PTFE with carbon; spring 1.4310			
Body gasket	Graphite with metal core			

¹⁾ DN 15 to 50 or NPS ½ to 2 only

²⁾ Seats for versions made of cast iron or cast steel in DN 65 or NPS 2½ and larger: 1.4006.
The seat is integrated into the stainless steel body in nominal sizes DN 65 to 100 or NPS 2½ to 4.

2 Installation

2.1 Assembling valve and actuator

The valve and the actuator are packed separately and must be assembled on site. To do this, proceed as follows:

2.1.1 DN 15 to 50 (Fig. 2)

1. Remove the nut (6) from the valve bonnet.
2. Slightly retract the actuator stem (8.1) and place the actuator with its rod-type yoke on the valve bonnet. Secure with the nut (SW 36). Observe a tightening torque of min. 150 Nm.
3. Extend the actuator stem until it touches the plug stem
4. Position the stem connector clamps and screw tight.

Caution!

Do not undo the rod nuts (8.3) on the rod-type yoke of actuators with 120 cm² diaphragm areas under any circumstances

For further details, refer to the mounting and operating instructions of the respective actuator.

2.1.2 DN 65 to 100

Pneumatic actuators with positioner
(Figs. 4 to 7)

1. Unscrew nut (2) from rod-type yoke of the actuator.
2. Place actuator (1) with the end of the rods onto the valve bonnet (3) and fasten with nuts (2), while holding the rods at the hexagonal surface stationary with an open-end wrench (SW 22).

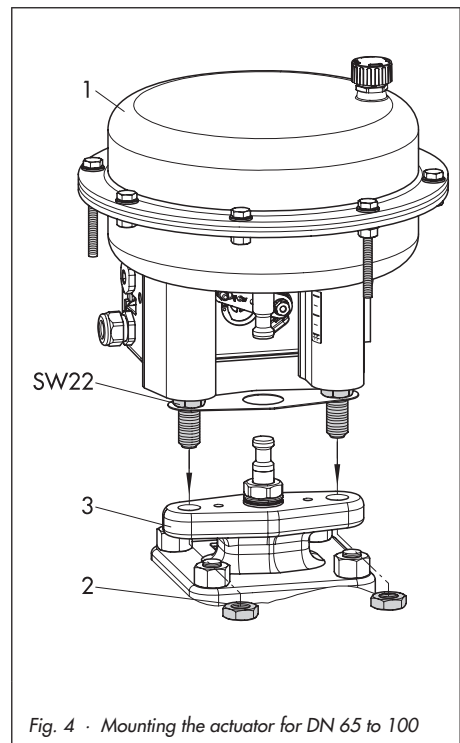

Fig. 4 · Mounting the actuator for DN 65 to 100



Caution!

Apply compressed air to actuators with fail-safe action "Actuator stem retracts" so that the actuator stem touches the plug stem.

Risk of injury!

Do not insert your hand into the yoke.

- Place the stem connector clamp with the travel pick-off (4 in Fig. 5) behind the actuator stem and loosely fasten together with the mating clamp (5) using the screws (6).

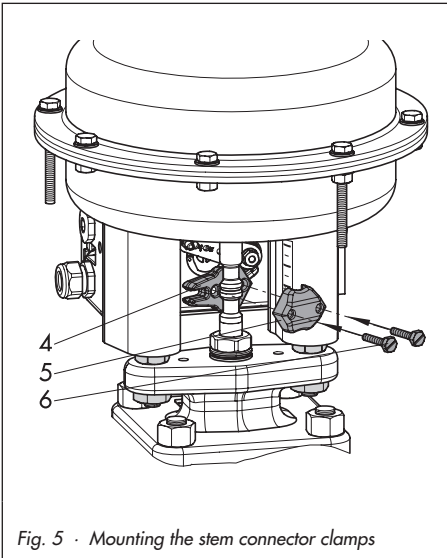

Fig. 5 · Mounting the stem connector clamps

- Pull the lever (7 in Fig. 6) downwards, overcoming the spring force. Turn the stem connector clamps so that the

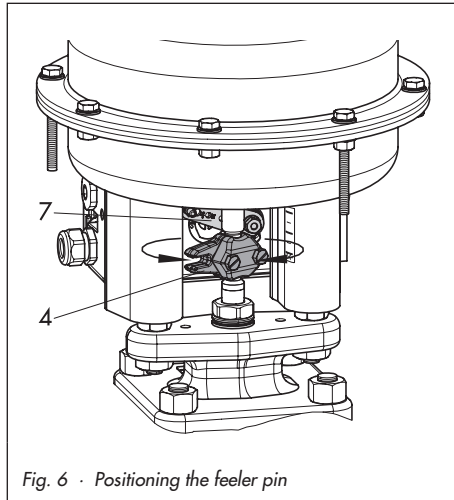

Fig. 6 · Positioning the feeler pin

follower pin of the lever is guided by the stem connector with travel pick-up (4).

- Tighten the screws (6 in Fig. 7) of the stem connector evenly.

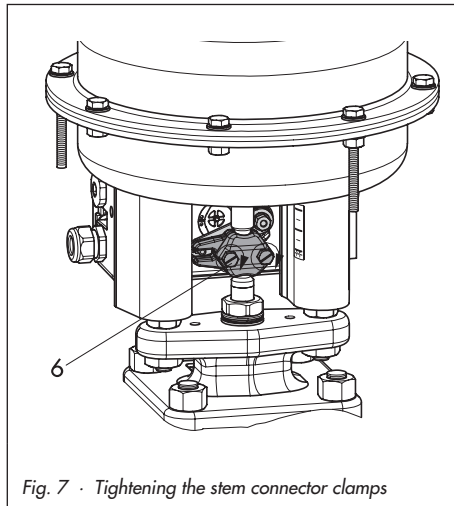
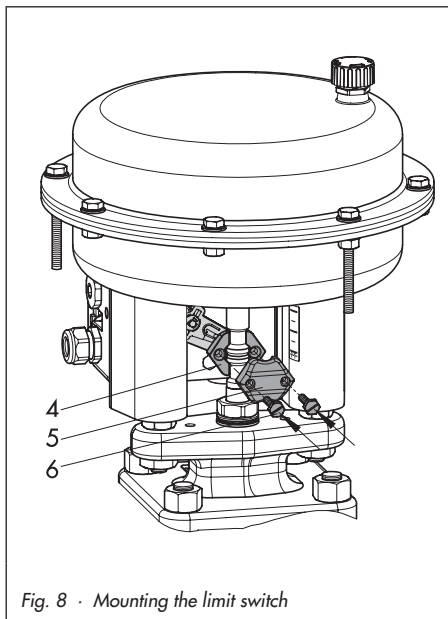

Fig. 7 · Tightening the stem connector clamps

Pneumatic actuator with Type 3776 Limit Switch (Fig. 8)

1. Place the stem connector clamp with pin behind the actuator stem, making sure that the pin engages into the long slot of the lever.
2. Position mating clamp and loosely fasten the clamps with screws (6).
3. Align stem connector and tighten screws.



Type 3374 Electric Actuator (Fig. 9)

1. Place actuator yoke onto the valve bonnet and fasten using two M8 hex socket screws.
2. Use the manual override to extend the actuator stem until it touches the plug stem.
3. Position stem connector clamps and screw tight.

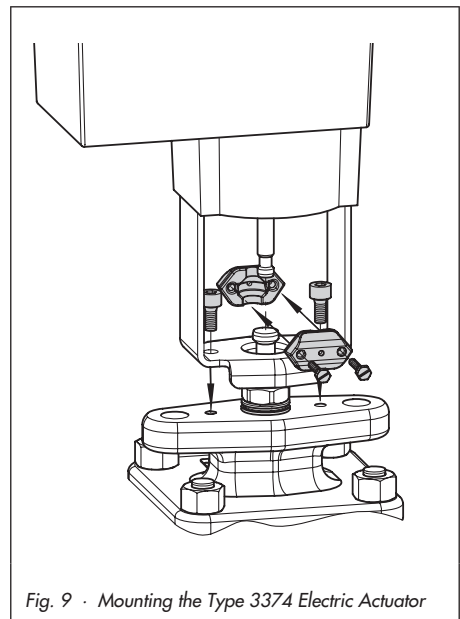

2.2 Mounting position

The valve can be mounted in any position. However, strictly observe the limitations resulting from the type of actuator used.

Caution!

The valve must be installed free of stress and free of excessive vibrations.

If necessary, support the pipelines near the connections.

Do not attach any supports to the valve or to the actuator.

Thoroughly flush the pipeline prior to installation of the valve to ensure that welding spatter or other impurities cannot impair the tight shut-off of the seat and plug.

2.3 Strainer

We recommend that you install a SAMSON Type 2 Strainer upstream of the valve.

We also recommend that you install a shut-off valve both upstream of the strainer and downstream of the control valve as well as a bypass line. This allows maintenance work to be carried out without having to shut down the plant.

3 Operation

As the operating instructions depend on the actuator used, refer to the corresponding mounting and operating instructions for detailed information.

4 Maintenance – Replacing parts

The control valve is subject to wear especially at the seat, plug, and packing.

Depending on the application conditions that prevail, the valve must be inspected at appropriately scheduled intervals to prevent any problems before they occur.

If any leaks occur to the atmosphere, the packing may leak. If the valve does not shut off properly, this may be because tight shut-off is prevented by dirt or other impurities between the seat and plug or because their facings have been damaged. We recommend removing the parts, thoroughly cleaning them, and replacing them with new parts, if necessary.



Caution!

If you intend carrying out maintenance work on the valve, first relieve the corresponding plant section of pressure and, depending on the process medium, drain it as well. Let the plant section cool down to reach ambient temperature, if necessary.

Prior to starting any work, disconnect the electric or pneumatic control signal for the actuator. Remove the signal pressure line on pneumatic actuators.

As the process medium cannot drain completely out of the valve, be aware that some of the process medium could still be in the valve. We recommend that you remove the valve from the pipeline.

Note!

The tightening torques and special tools required for installing and removing the seat are listed in the table on page 12. For further details, refer to the SAMSON Special Tools WA 029 EN.

Important! (Fig. 2)

Always separate the actuator and the valve prior to carrying out repairs!

Separate the actuator with 120 cm² diaphragm area from the valve by removing the stem connector clamps (7) and the nut (6). Then lift the actuator off the valve. Do not undo the rod nuts (8.3) of the rod-type yoke under any circumstances.

4.1 Packing (Fig. 2)

1. Unscrew the nuts (1.1) and remove the valve bonnet (5) and flange (5.1).
2. Check the gasket (1.2) in the valve body for damage. We recommend that you replace the gasket.
3. Screw off the threaded bushing (5.2) and pull out the plug (3).
4. Pull out the damaged packing (4.2) using an appropriate tool. Remove the washer (4.3) and spring (4.1) and clean the packing chamber.
5. Apply lubricant (order no. 8150-0111) to the individual parts of the new packing and the plug stem. Insert the plug (3) in the valve bonnet (5).
6. Place the valve bonnet with flange on the valve body and secure with nuts (1.1). Observe the tightening torques listed in the table.

7. Insert the spring (4.1) and washer (4.3) and carefully slide the new packing (4.2) over the plug stem into the packing chamber. Screw in the threaded bushing (5.2) and tighten.

4.2 Plug (Fig. 2)

When replacing the plug, we recommend also replacing the packing (4.2) and the gasket (1.2) with new ones.

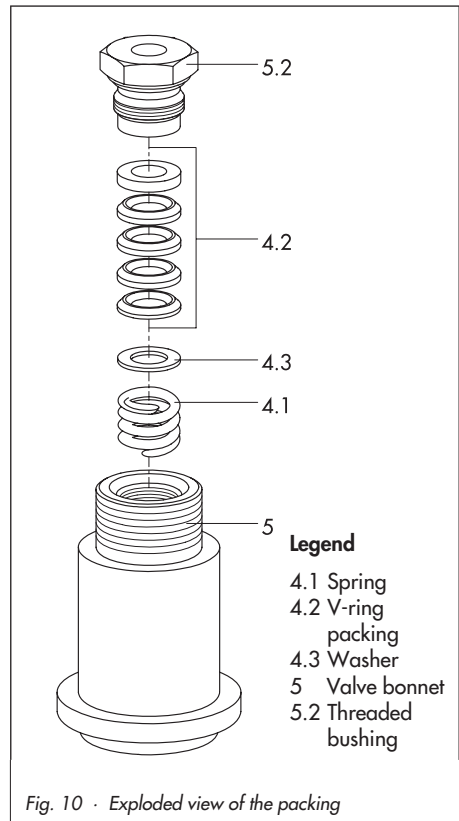

Fig. 10 · Exploded view of the packing

1. To exchange the plug, carry out the same steps as described in section 4.1.
2. However, install a new plug instead of the used one.
3. Apply lubricant (order no. 8150-0111) to the plug stem prior to installation.
3. Apply lubricant (order no. 8150-0119) to the thread and the sealing cone of the new seat and screw in.
4. Place the valve bonnet with flange on the valve body and secure with nuts (1.1). Observe the tightening torques!

4.3 Seat (Fig. 2)

1. Unscrew the nuts (1.1). Lift the valve bonnet (5) and flange (5.1) off the valve body (1).
2. Unscrew the seat (2) using the appropriate seat wrench.

Table 2 · Seat wrench and tightening torques

Nominal size	DN 15 ... 25 NPS ½ ... 1	DN 32 ... 50 NPS 1 ½ ... 2	DN 65 ... 80 NPS 2 ½ ... 3	DN 100 NPS 4
Seat tool order no.	1280-3030	1280-3009 (socket only)	9110-2467	9110-2471
Also requiring	–	Support flange 1490-6707	9932-3800 9932-3814	9932-3800 9932-3814
Seat thread Tightening torque ±10 %	M32 x 1.5 170 Nm	M58 x 1.5 500 Nm	M90 x 1.5 ¹⁾ 1050 Nm	M110 x 1.5 ¹⁾ 1550 Nm
Body nuts (1.1) Tightening torque +10 %	M10 10 Nm	M12 30 Nm	M16 60 Nm	M20 100 Nm

¹⁾ Not required for stainless steel valve bodies

5 Description of nameplate

The nameplate contains all the necessary specifications to identify the valve.

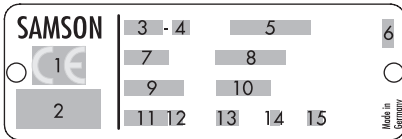

Fig. 11 · Nameplate

Legend

- 1 CE marking or "Art. 3, Abs.3" (see article 3, § 3 of PED), where applicable
- 2 Identification no. of notified body, fluid group and category, where applicable
- 3 Type designation
- 4 Modification index of valve
- 5 Material
- 6 Year of manufacture
- 7 Nominal size: DIN: DN; ANSI: NPS
- 8 Permissible excess pressure at room temperature
DIN: bar, ANSI: Class
- 9 Order number with modification index
- 10 Position of item in order
- 11 Flow coefficient
DIN: K_{VS} , ANSI: C_V
- 12 Characteristic:
% equal percentage, Lin linear,
DIN: **A/Z** quick opening, ANSI: **O/C**
- 13 Sealing:
ME metal, **ST** stellited, **Ni** nickel-plated
PT soft sealing with PTFE,
PK soft sealing with PEEK
- 14 –
- 15 I or III flow divider

6 Dimensions and weights

Type 3321 Valve without actuator

DIN version	DN	15	20	25	32	40	50	65	80	100
L	mm	130	150	160	180	200	230	290	310	350
H	mm	160			165			210		233
Weight	kg	5	6	7	11	12	15	24	30	42

ANSI version	NPS	½	¾	1	–	1½	2	2½	3	4
L [in]	Cl 150	7.25			–	8.75	10.0	10.87	11.75	13.87
	Cl 300	7.5	7.62	7.75		9.25	10.5	11.5	12.5	14.5
H	in	6.3			–	6.5		8.3		9.2
Weight	lbs	11	13	15		–	26	33	53	66

* Valve CLOSED

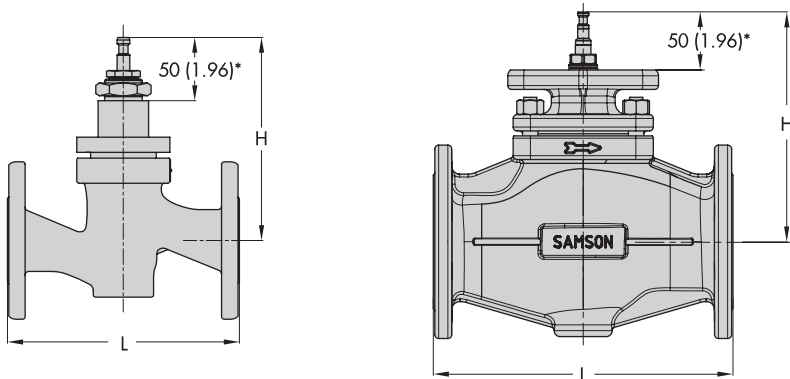

Fig. 12 · Dimensional drawings for DN 15 to 50 and DN 65 to 100 · NPS ½ to 2 and NPS 2½ to 4

7 Customer inquiries

If you encounter any problems, please submit the following details:

- ▶ Type designation and order number (indicated on the nameplate)
- ▶ Production number, nominal size, and valve version
- ▶ Pressure and temperature of the medium
- ▶ Flow rate in m³/h
- ▶ Bench range (signal pressure range, e.g. 1.4 to 2.3 bar) of the pneumatic actuator
- ▶ Installation drawing



SAMSON AG · MESS- UND REGELTECHNIK
Weismüllerstraße 3 · 60314 Frankfurt am Main · Germany
Phone: +49 69 4009-0 · Fax: +49 69 4009-1507
Internet: <http://www.samson.de>

EB 8111/8112 EN

2006-09