

# Electric Control Valves/Controller with Electric Actuator Types 3226/5757, 3226/5724, 3226/5725

## Three-way Valve Type 3226



### Application

Three-way valves as a mixing or flow-diverting valve in heating, ventilation, and air-conditioning systems.

DN 15 to DN 50, G ½ to G 1 · PN 25 · Version up to 150 °C  
(for water and non-flammable gases)



The control valves consist of a Type 3226 Three-way Valve and either a Type 5757, Type 5724 or Type 5725 Controller with Electric Actuator (Type 5725 with safety function).

### Special features

- Type 3226 Three-way Valve designed as a **diverting valve** with welding ends or threaded ends (DN 15 to 50)
- Type 3226 Three-way Valve designed as a **mixing valve** with welding ends or threaded ends (DN 15 to 50) or screwed ends with female thread (G ½ to G 1)
- Type 3226 Three-way Valve mounted on a Type 5757/-7 Controller with Electric Actuator in special version
- Force-locking connection between valve and actuator
- Special version: DVGW-tested

### Versions

For DHW heating in instantaneous heating systems and mechanical engineering applications		
Type 3226/5757 · Fig. 1	PN 25	DN 15 to 25 G ½ to G 1
Type 3226/5724 · Fig. 2	PN 25	DN 15 to 50 G ½ to G 1
Type 3226/5725 <sup>1)</sup>	PN 25	DN 15 to 50 G ½ to G 1
For heating applications		
Type 3226/5757-7	PN 25	DN 15 to 25 G ½ to G 1

- 1) Electric control valve with safety function  
Port B of the mixing valve closes when the safety function is triggered (see Fig. 5)  
Port A of the diverting valve closes when the safety function is triggered (see Fig. 5)

### Also available:

- Type 3226 Three-way Valve with electric or pneumatic actuator (refer to Data Sheet T 5863 EN)
- Three-way valve with flanges, mounted on a controller with electric actuator (refer to Data Sheet T 5761 EN)
- Three-way valve with flanges and electric or pneumatic actuator (refer to Data Sheet T 5861 EN)



Fig. 1 · Type 3226/5757 (version with female thread)



Fig. 2 · Type 3226/5724 (version with female thread)

### Principle of operation (Fig. 3)

The three-way valve in the version with welding and threaded ends is available as a mixing or flow-diverting valve. The valves vary in the plug arrangement and must be installed accordingly. The version with female thread is only available as a mixing valve. The valve and actuator have a force-locking connection.

The position of the plug (3) determines the cross-sectional area of flow between the plug and the seat (2). The plug stem follows the actuator stem, which is changed by the control signal acting on the actuator, owing to the force of the valve spring (5).

The electric actuator contains a digital controller integrated into the actuator. The controlled variable is measured over the directly connected Pt 1000 sensor. The output signal of the digital controller acts as a three-point stepping signal on the synchronous motor of the actuator and is transferred over the connected gear as a positioning force onto the actuator stem.

**Type 5725 with safety function** · The Type 5725 Controller with Electric Actuator is equipped with a spring assembly and an electromagnet that can be connected to a safety interlock circuit. When the control circuit is interrupted or the power supply fails, the magnet disengages the gear from the self-locking motor and releases the spring assembly. The actuator has the fail-safe action "Actuator stem extends".

Refer to Data Sheet for details	
Type 5757-7	-> Data Sheet T 5757-7 EN
Type 5757	-> Data Sheet T 5757 EN
Type 5724/5725	-> Data Sheet T 5724 EN

### Installation

The control valves can be mounted in any position. However, the actuators must not be suspended downwards.

Make sure that the maximum ambient temperature of 50 °C for the actuator, which is attached to the valve bonnet, is not exceeded.

Make sure that the inlet and outlet flows of the plant are correctly assigned to ports A, B, and AB. Fig. 5 schematically illustrates a few typical applications.

Strainers must be installed upstream of the inlets of valves mounted on actuators with safety function (e.g. Type 1N or Type 1FN).

### Ordering text

Electric control valve/Controller with electric actuator  
Type 3226/5757-7, 3226/5757, 3226/5724, 3226/5725

DN ..., G ..., PN 25

Mixing valve or diverting valve

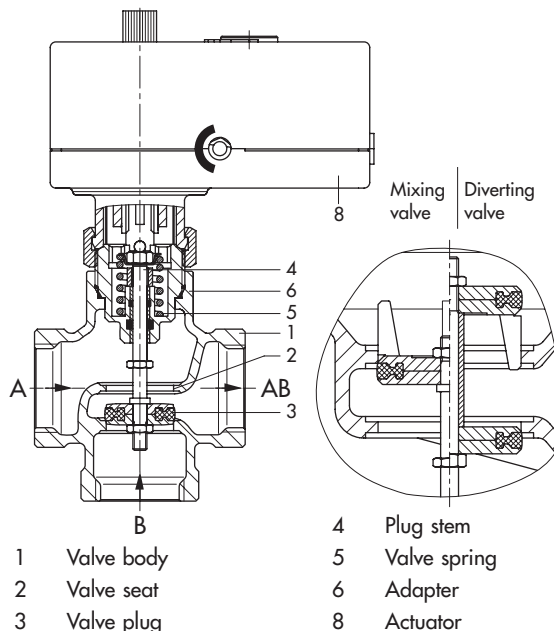

Fig. 3 · Functional diagram of Type 3226/5757 (left) as a mixing valve (DN 15 to 25) · Plug arrangement (right) for version with male thread (mixing and diverting valve)

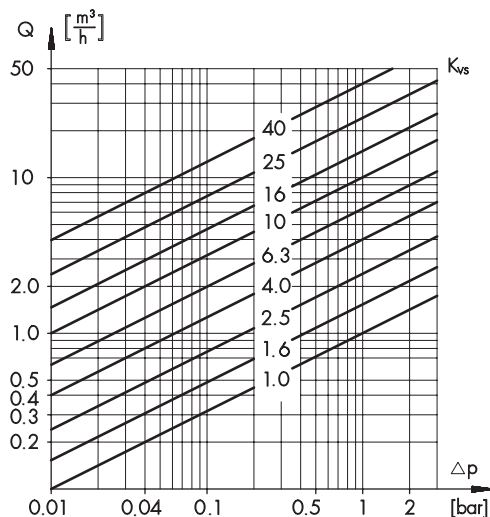

Fig. 4 · Flow rate diagram for water

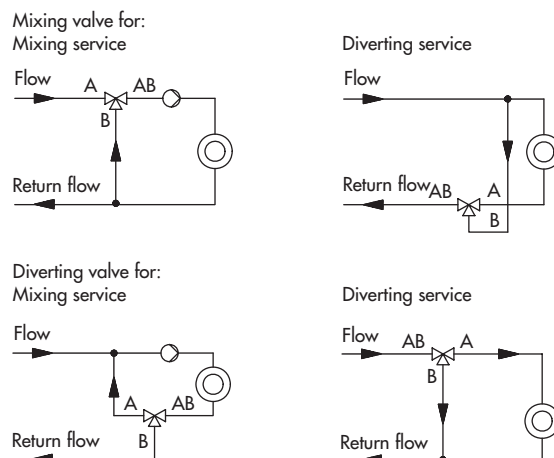

Fig. 5 · Typical installations

**Table 1 · Technical data** · All pressures in bar (gauge)

<b>Thread size</b>	Mixing valve with female thread	G	½	¾	1			
<b>Nominal size</b>	Mixing or diverting valve with welding ends or threaded ends	DN	15	20	25	32	40	50
Nominal pressure		PN	25					
	DVGW version	PN	10					
Permissible temperature		°C	5 to 150 <sup>1)</sup>					
	DVGW version	°C	5 to 90 <sup>2)</sup>					
Permissible max. differential pressure		bar	4	4	4	1.7	1.1	1.1
Rated travel		mm	6			12		
Seat/plug sealing	Soft sealing							
Leakage rate acc. to DIN E1N 1349	Class IV (≤ 0.05 % of K <sub>VS</sub> )							
<b>Materials</b>								
Valve body	CC491K (G-CuSn5ZnPb)							
Plug	CW617N (CuZn40Pb2Zn) with EPDM							
Packing	O-rings made of FKM and EPDM							
Welding ends	St 37							
Threaded ends	Red brass							
Screw-on flanges	St 37.2							

1) Use an intermediate insulating piece for networks with constant medium temperatures between 130 and 150 °C

2) **Special version DVGW-tested:** Only as diverting valve

**Special version DVGW-compliant** (materials and lubricants same as DVGW-tested): Only as mixing valve

**Table 2 · Overview: Nominal sizes, K<sub>VS</sub> coefficients and maximum differential pressures**

<b>Thread size</b>	Mixing valve w. female thread	G	½				¾	1			
<b>Nominal size</b>	Mixing or diverting valve with welding ends or threaded ends	DN	15				20	25	32	40	50
K <sub>VS</sub>			1.0	1.6	2.5	4	6.3	10	16	25	40
Rated travel		mm	6					12			

**Table 3 · Possible combinations for Type 3226 Three-way Valve<sup>1)</sup>/controller with electric actuator**

Type	Refer to Data Sheet for details	Thread size/nominal size					
		½	¾	1			
		15	20	25	32	40	50
5757	T 5757 EN	•	•	•	–	–	–
5757-7	T 5757-7 EN	•	•	•	–	–	–
5724-10	T 5724 EN	•	•	•	–	–	–
5724-13		•	•	•	–	–	–
5724-20		–	–	–	•	•	•
5724-23		–	–	–	•	•	•
5725-10		•	•	•	–	–	–
5725-13		•	•	•	–	–	–
5725-20		–	–	–	•	•	•
5725-23		–	–	–	•	•	•

1) Type 3226/5757 and Type 3226/5757-7 Control Valves require a special version of Type 3226 Valve.

**Table 4 · Dimensions and weights**

Table 4.1 · Dimensions and weights without controller with electric actuator							
Thread size	G	1/2	3/4	1	-	-	-
Nominal size	DN	15	20	25	32	40	50
Height H2	mm	51	51	51	61	61	61
<b>Valves with female thread</b>							
Thread size R1	G	1/2	3/4	1	-	-	-
Length L1	mm	65	75	90	-	-	-
Height H1	mm	40	40	40	-	-	-
Width across flats SW1		27	34	46	-	-	-
Weight, approx.	kg	0.9	1.1	1.3	-	-	-
<b>Valves with male thread</b>							
Thread size R	G	3/4	1	1 1/4	1 3/4	2	2 1/2
Width across flats SW		30	36	46	59	65	82
Length L	mm	65	70	75	100	110	130
Height H3	mm	40	40	40	60	65	65
<b>Valves with welding ends</b>							
Pipe Ød	mm	21.3	26.8	33.7	42	48	60
Length L2	mm	210	234	244	268	294	330
Height H4	mm	112	122	124	149	162	175
Weight, approx.	kg	3.2	3.6	4.0	6.1	7.0	8.0
<b>Valves with thread ends</b>							
Male thread A	G	1/2	3/4	1	1 1/4	1 1/2	2
Length L3	mm	128	143	158	179	195	227
Height H5	mm	71.5	76.5	81.5	99	108	114
Weight, approx.	kg	3.2	3.6	4.0	6.1	7.0	8.0

Table 4.2 · Weights of controllers with electric actuators				
Type	5724	5725	5757	
Weight, approx.	kg	1.1	1.3	0.7

**Dimensions in mm**

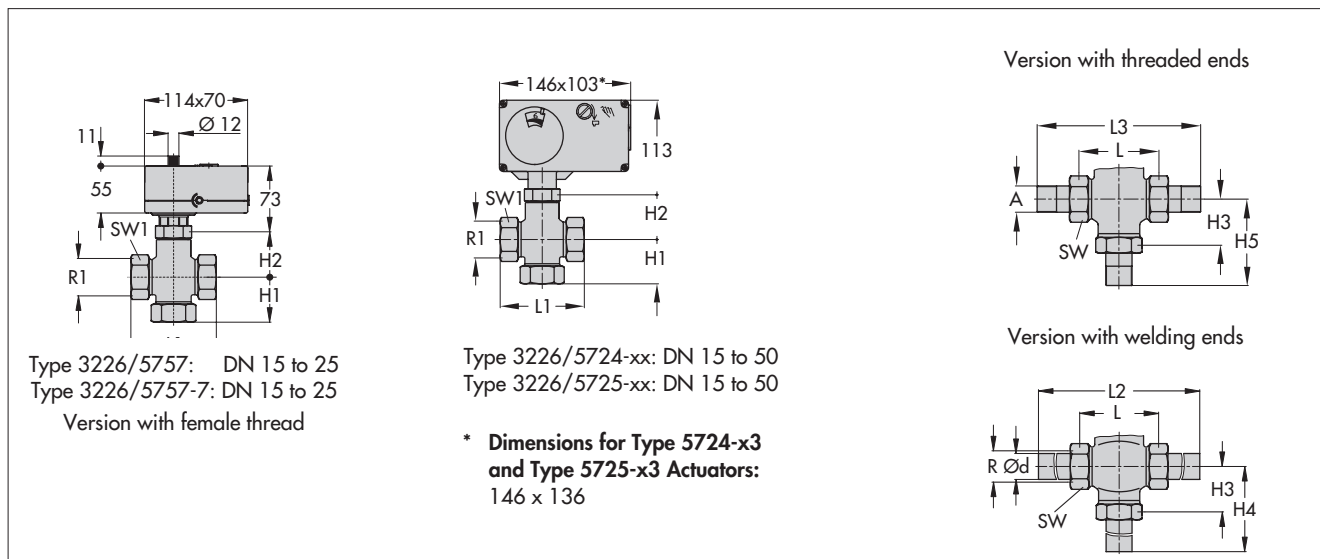

Specifications subject to change without notice.

