

Steripur 592

Pneumatically Operated Valve DN 15 - 50 mm (1/2" - 2")

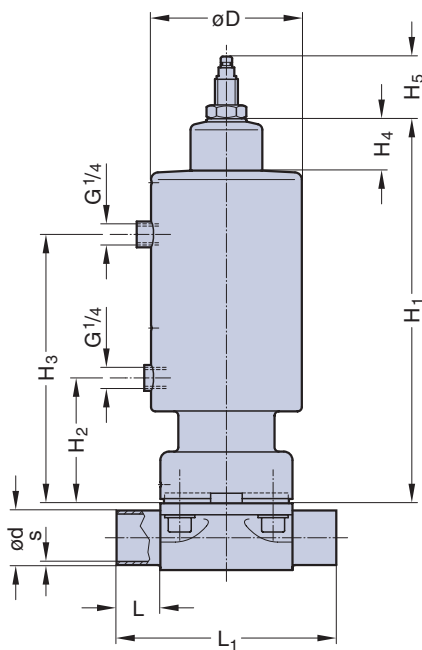

DN 50 Cf. 4



Features

- Two stage stainless steel actuator
- Second position adjustable with reduced flow for filling
- Compact design, the outside diameter of the actuator is the same size as the bonnet flange
- Advantages in multiport bodies and manifold valve assemblies
- Control air connection in flow direction
- Circumferential, defined sealing angle between process diaphragm and valve body
- Flexible diaphragm suspension
- Encapsulated diaphragm
- Clean and polished exterior design ideal for sterile wash downs
- Optical indicator

Optional

- Available with a wide range of control equipment and accessories see page 59 to 64, also for retrofitting
- Control air connection 90° to flow direction
- Autoclavable

Technical Data

Control function (Cf.): Pneumatically operated
Fail safe close (NC): Cf. 1 & 4

Direction

Control connection: At Cf. 4 in flow direction, standard
At Cf. 1, 90° to flow direction

Max. working pressure: Unidirectional ($\Delta p = 100\%$)

Diaphragm	DN 15 - 50 (2")
EPDM	10 bar (150 psi)
PTFE	8 bar (120 psi)

Higher working pressure may be achieved with different actuator. Please consult a SED factory representative for working pressure above the indicated maximum.

Max. working temperature: 160°C (320°F) dependent on application

Control pressure: Cf. 1 & 4 5 - 8 bar (70 - 120 psi)

Diaphragm material: EPDM or PTFE

Valve body material: Forged 1.4435/ 316 L ASME/BPE

Investment cast 1.4435/ 316 L

Other alloys

End connection: Butt weld ends see fold out page 15
Clamps and flanges see page 16 and 17
Special ends

Actuators suitable for: Two-Way bodies
Welded configurations
T-bodies
Multiport bodies
Tank bottom bodies

Flow rate: Kv in m³/h (Cv in GPM) see page 9

Diaphragm size: MA see table below

DN (mm)	Dimensions (mm)									
	MA	L	L ₁	A x B	H ₁	H ₂	H ₃	H ₄	H ₅	D
15-25	25	25	120	73x79	220	66	150	-	35	75
32-40	40	25	153	96x105	250	75	185	28	40	105
50	50	30	173	110x130	294	77	221	28	47	105

Type 592 is also available in MA 10 as type 392.

Butt weld ends
MA 25 - 100
Fold out page 15